

		CHRONOFASH 20 A																
S		9,4	10,1	11	11,7	12,7	13	14	15	16	17	18	19	20	21	22	23	24
V	24 m	2000	1810	1630	1500	1350	1310	1200	1100	1010	930	870	810	760	710	670	630	600
	22 m		2000	1800	1670	1500	1460	1330	1220	1120	1040	970	900	850	800	750		
	20 m		2000	1800	1670	1500	1460	1330	1220	1120	1040	970	900	850				kg



**TRANSPORT  
ROUTIER**

**TRANSPORT  
STRASSE**

**TRANSPORT  
ROAD**

**TRASPORTO  
SU STRADA**

**TRANSPORTE  
RUTA**

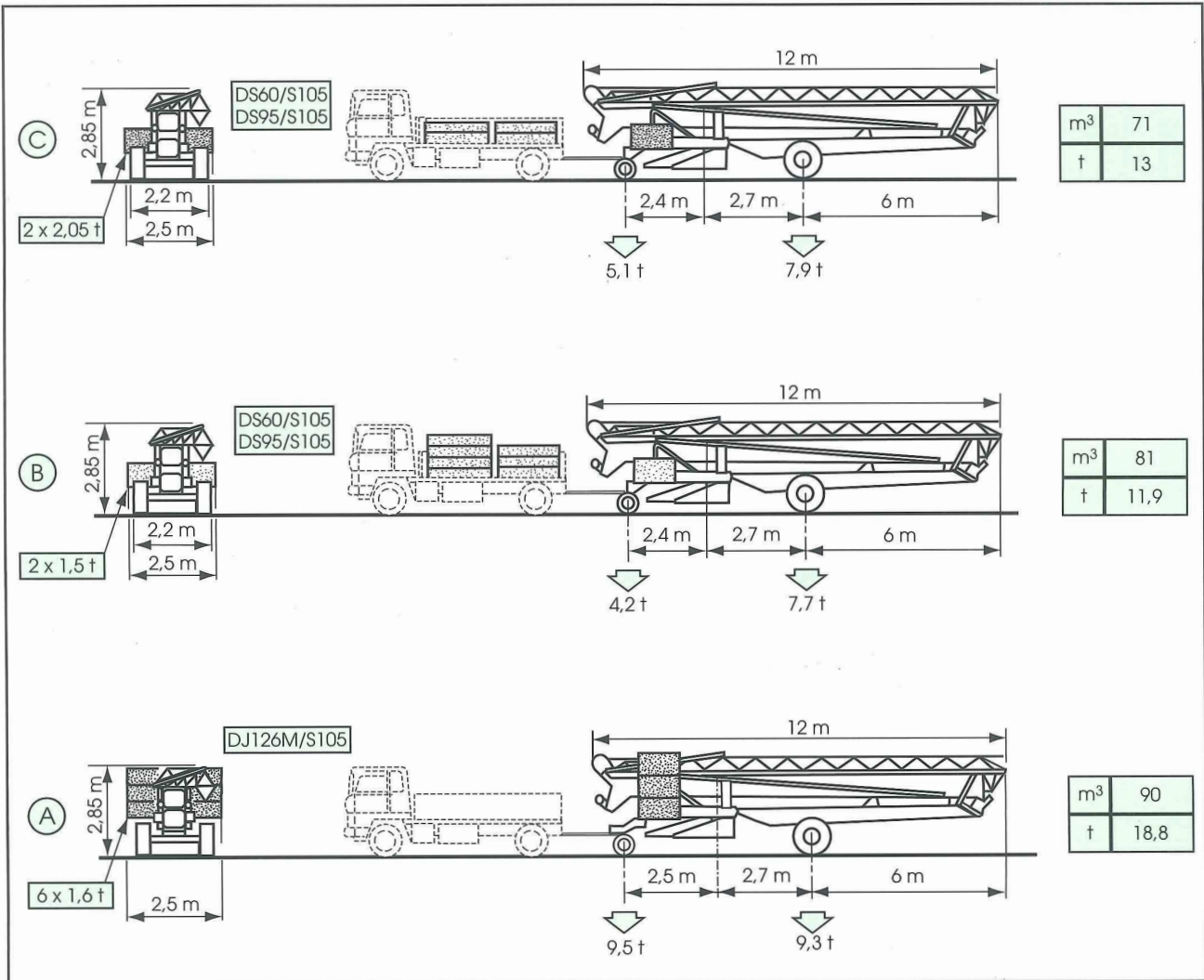

**SUR  
CAMION**

**AUF  
LKW**

**ON  
LORRY**

**SU  
CAMION**

**SOBRE  
CAMION**

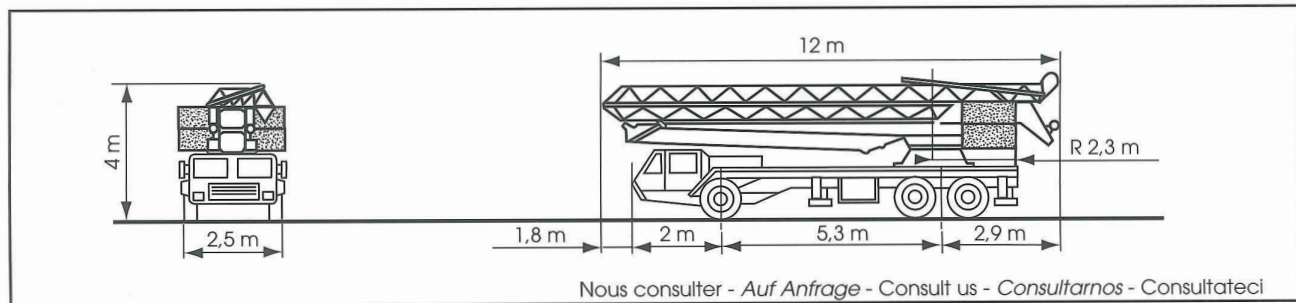

Modificaciones reservées - Änderungen vorbehalten - Subject to modification - Modificaciones reservadas