

Transportgewicht ca. 31500 kg  
Transport weight approx.  
Poids de transport env.

# Gewicht

## Weight

### Poids

Max. Eckkraft in Betrieb Max. corner pressure in operation Réaction maxi. par angle en service	425 kN*
Max. Eckkraft außer Betrieb Max. corner pressure out of operation Réaction maxi. par angle hors service	310 kN*

Gegengewicht ca. Counter weight approx. Contrepoids env.	44000 kg
Konstruktionsgewicht (max. Ausladung + Hakenhöhe) ca. Dead weight (max. radius + hook height) approx. Poids de la construction (max. portée + hauteur sous crochet) env.	28300 kg

\* Umrechnung der Einheiten für Kräfte 1 kp ≈ 10 N; 10 kN ≈ 1 Mp./Conversion of the units for forces./Conversion des unités des forces.

# Ausladung und Tragfähigkeit

## Radius and capacity / Portée et charge

Auslegerlänge Length of jib Longueur de flèche m	max. kg m/kg		m/kg																				
			21,0	22,0	24,0	26,0	28,0	30,0	31,0	32,0	33,0	35,0	36,0	37,0	38,0	40,0	41,0	42,0	43,0	45,0	46,0	48,0	50,0
50,0	3,9-20,1 4000		3800	3590	3220	2920	2670	2450	2350	2260	2170	2020	1950	1880	1820	1700	1650	1600	1550	1460	1420	1340	1270
45,0	3,9-23,5 4000		4000	4000	3890	3530	3230	2970	2850	2750	2640	2450	2380	2300	2220	2090	2020	1960	1910	1800			
40,0	3,9-27,5 4000		4000	4000	4000	4000	3910	3600	3460	3330	3210	3000	2900	2800	2710	2550							
35,0	3,9-29,7 4000		4000	4000	4000	4000	4000	3960	3810	3670	3540	3300											

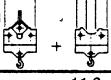

m	max. kg m/kg		m/kg																				
			21,0	22,0	24,0	26,0	28,0	30,0	31,0	32,0	33,0	35,0	36,0	37,0	38,0	40,0	41,0	42,0	43,0	45,0	46,0	48,0	50,0
50,0	3,9-18,9 4000	-11,6 8000	3660	3440	3070	2760	2500	2270	2170	2080	2000	1800	1760	1700	1630	1510	1460	1410	1360	1270	1220	1140	1070
45,0	3,9-21,9 4000	-13,2 8000	4430	4170	3730	3360	3060	2790	2670	2560	2460	2250	2190	2110	2030	1890	1830	1770	1710	1600			
40,0	3,9-25,8 4000	-14,8 8000	5150	4860	4350	3930	3580	3280	3140	3020	2900	2690	2590	2500	2410	2250							
35,0	3,9-28,7 4000	-16,4 8000	5870	5550	4980	4510	4110	3770	3620	3470	3340	3100											

m	max. kg m/kg		Auslegersteilstellung 30° Elevated jib 30° Flèche inclinée 30° m/kg																				
			22,0	23,0	24,0	25,0	26,0	27,0	28,0	29,0	30,0	30,6	31,0	32,0	33,0	34,0	34,9	35,0	36,0	37,0	38,0	39,0	39,3
45,0	3,7-18,2 4000		3150	2980	2830	2690	2560	2440	2330	2230	2130	2080	2040	1960	1890	1810	1750	1750	1680	1620	1570	1520	1500
40,0	3,7-21,9 4000		3980	3770	3580	3410	3250	3100	2960	2840	2720	2640	2610	2510	2420	2330	2250						
35,0	3,7-24,8 4000		4000	4000	4000	3960	3780	3610	3460	3310	3180	3100											

# Geschwindigkeiten

## Speeds / Vitesses

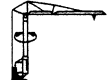
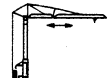
	U/min 0 - 0,8 sl./min tr./min	4,0 kW
	10,0 / 33,0 / 67,0 m/min	5,0 kW
	25,0 m/min	2 x 2,0 kW
	0 - 45° ca. 2 min.	6,0 kW

Leitungsquerschnitt bei 380 V  
Cross section of cable  
Section de câble à

bis 96 m  
up to  
jusqu'à

4 x 25 mm<sup>2</sup>

Betriebsspannung 380 V  
Operating voltage  
Tension de service

Frequenz 50 Hz  
Frequency  
Fréquence

Technische Kenngröße nach BGL 81  
Technical nominal size according to the construction machinery list (BGL)  
Grandeur caractéristique suivant le barème d'emploi des appareils (BGL)

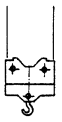
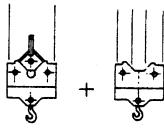
Hubwerk Hoist unit Mécanisme de levage	Stufe Step Cran	kg	m/min
24,0 kW 	1	4000	6,5
	2	4000	30,0
	3	2000	60,0
	1	4000 8000	6,5 3,25
	2	4000 8000	30,0 15,0
	3	2000 4000	60,0 30,0

Anschlußwert 43,0 kVA  
Power requirement  
Puissance requise

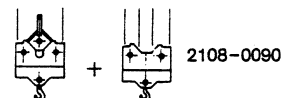
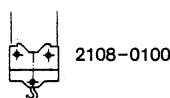

# Aufstellvorgang

## Erection procedure

### Déroulement de montage

Ballastierausladung 5,4 m  
 Ballasting radius 5,4 m  
 Portée pour dispositif de lestage 5,4 m

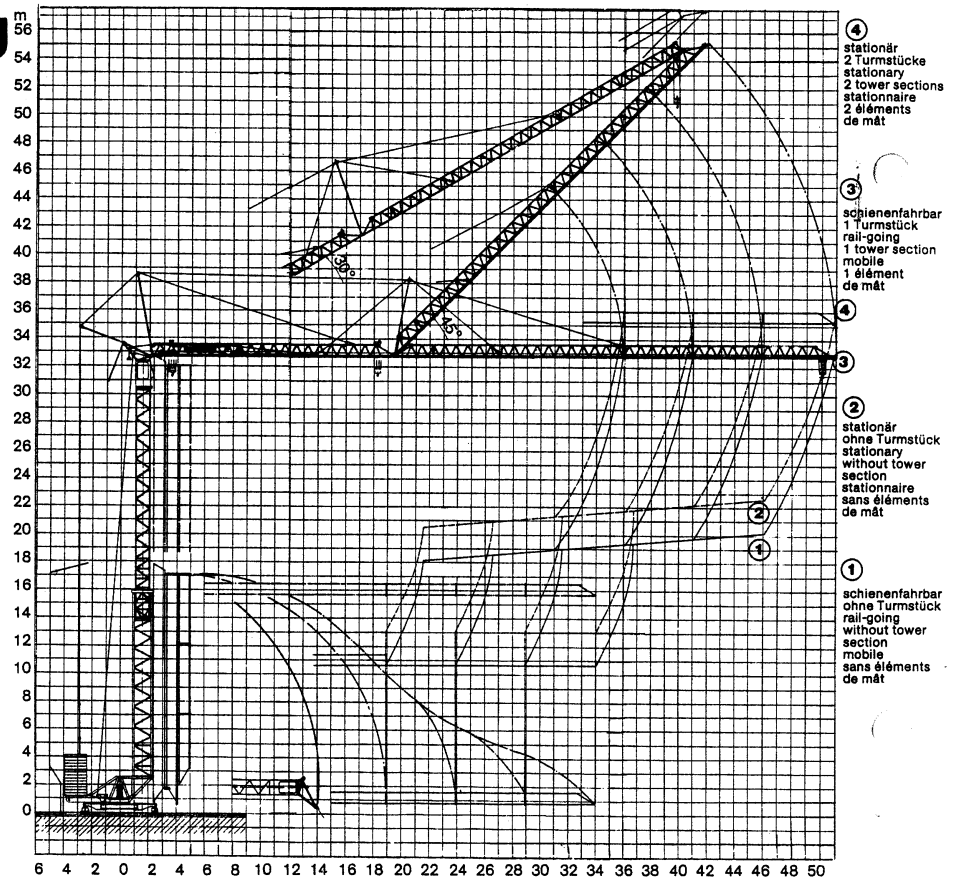

# Kolli-Liste

## Packing List

### Liste de colisage

Pos. Item Rep.	Anz. Qty. Qté			L (m)	B (m)	H (m)	kg
1	2	Turmstück (mit Turmauflage) Tower section with tower support Élément de mât avec support de mât		2,52	1,11	1,11	780
2	1	Ausleger-Verlängerung 35,0 m – 40,0 m Jib extension Rallonge de la flèche		5,24	1,02	0,99	350
3	1	Ausleger-Verlängerung 40,0 m – 45,0 m Jib extension Rallonge de la flèche		5,16	1,02	0,92	220
4	1	Ausleger-Verlängerung 45,0 m – 50,0 m Jib extension Rallonge de la flèche		4,73	1,02	0,89	170
5	1	Transportachse Tra 200 GZ 3 Road transport axle Essieux de transport		3,10	2,50	1,10	2500
6	1	Kiste mit Seilen und Kleinteilen Case with ropes and small parts Caisse avec câbles et pièces détachées		1,00	0,80	1,00	450

Datenblatt Nr. 120 P – 2582 FEM (Section 1) – Gruppe 3 • 04.94  
 Data sheet  
 Feuille de caractéristiques

Konstruktionsänderungen vorbehalten!  
 Subject to alterations!  
 Sous réserves de modifications!